

FIRST BASE

V-76 Round Flange 8x200mm M16 – 89mm 3x M16

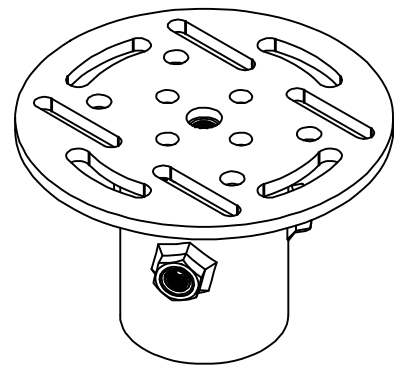

Art. No:	58222	
Weight:	3,1 kg	
Dimensions:	Pipe: 88,9 x 5,5 x 120 mm Flange: 8 x 200 mm	
Materials:	Steel grade Pipe: S235 Steel grade Flange: S355 Surface treatment: Galvanized acc. to EN-ISO 1461	
Installation:	Electric machine 5.500Nm	Art.No: 12001
	Pneumatic machine 10.800Nm	Art.No: 12005
	Hydraulic machine 7.500Nm	Art.No: 120950
	Hydraulic machine 12.000Nm	Art.No: 120960
Use:	Construction e.g. porches, garden rooms and modular homes.	
Fixation:	M16 Bolts	
Products to combine:	58201 V-76 x 1200 SCREW PART 58202 V-76 x 2100 SCREW PART 58211 V-76 EXTENSION 500mm 58212 V-76 EXTENSION 1000mm 58213 V-76 EXTENSION 1500mm 58214 V-76 EXTENSION 2000mm	



3D view (1 : 4)

[Click here](#) for the FIRST BASE Load Capacity Chart

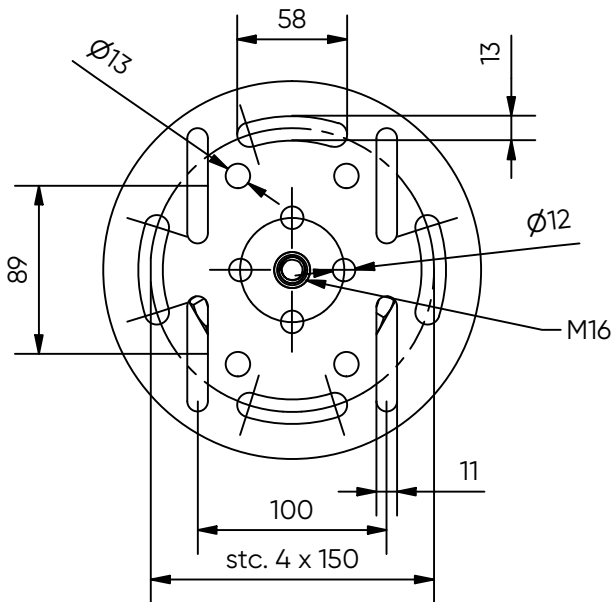

C (1 : 4)

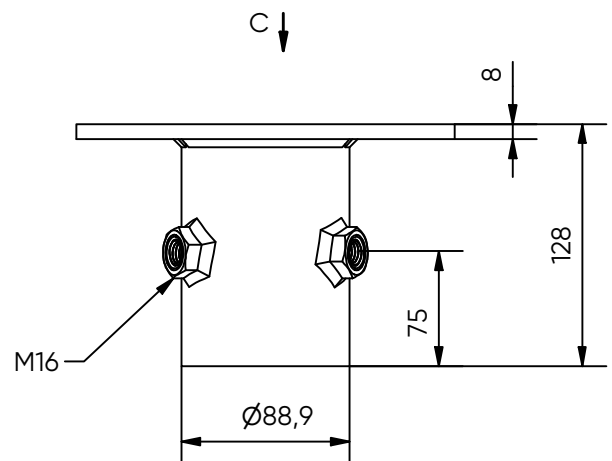

CE-certificate conform EN1090