

FIRST BASE Ground Screw

G3 Ø89 x 3,6 x 1500mm, Nut 3 x M16



Art. No:	31033	
Weight:	10,9 kg	
Dimensions:	Pipe: 89 x 3,6 x 1500 mm	
Materials:	Steel grade Pipe: S235 Surface treatment: Galvanized acc. to EN-ISO 1461	
Installation:	Electric machine 5.000Nm	Art.No: 12001
	Pneumatic machine 10.800Nm	Art.No: 12005
	Hydraulic machine 7.500Nm	Art.No: 120950
	Hydraulic machine 12.000Nm	Art.No: 120960
Use:	Light construction e.g. Solar Field-setups	
Fixation:	M16 Bolts	
Products to combine:		

[Click here for the FIRST BASE Load Capacity Chart](#)

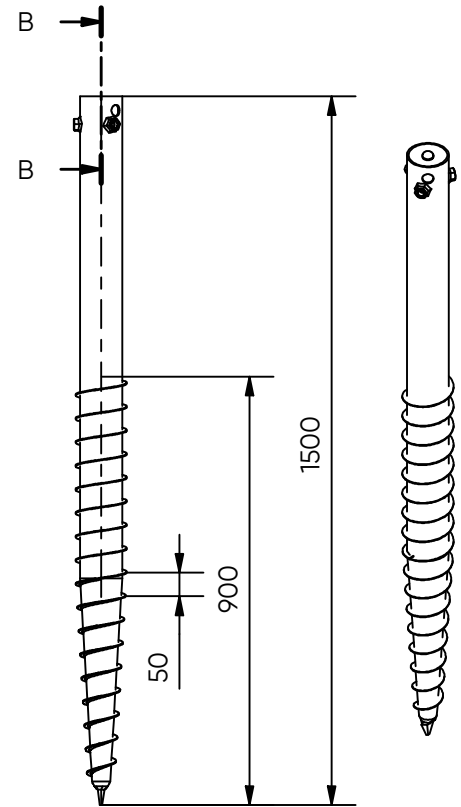

Side view (1 : 16)

3D view (1 : 16)

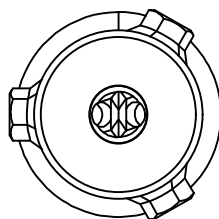

Top view (1 : 4)

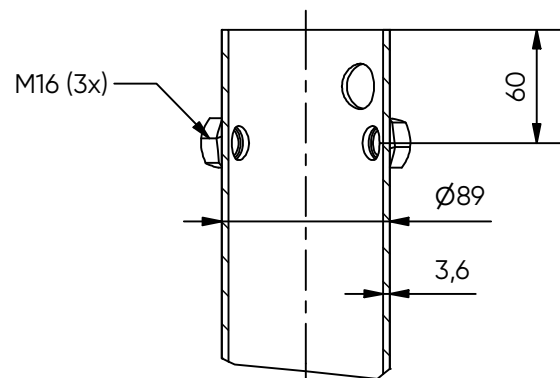

B-B (1 : 4)

CE-certificate conform EN1090