

# FIRST BASE Ground Screw

## G3 Ø89 x 3,6 x 800mm, Nut 3 x M16

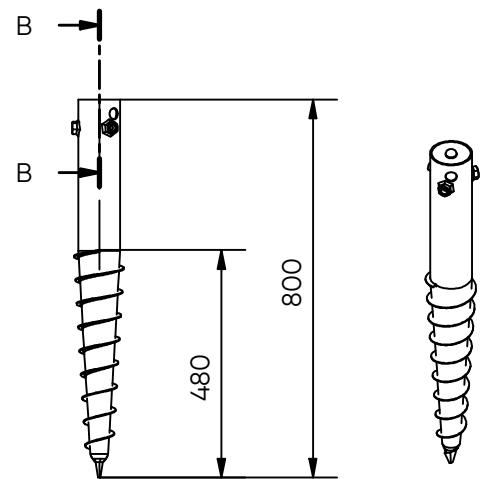

Art. No:	31030	
Weight:	5,2 kg	
Dimensions:	Pipe: 89 x 3,6 x 800 mm	
Materials:	Steel grade Pipe: S235 Surface treatment: Galvanized acc. to EN-ISO 1461	
Installation:	Electric machine 5.000Nm Art.No: 12001	Pneumatic machine 10.800Nm Art.No: 12005
	Hydraulic machine 7.500Nm Art.No: 120950	Hydraulic machine 12.000Nm Art.No: 120960
Use:	Light construction e.g. Solar Field-setups	
Fixation:	M16 Bolts	
Products to combine:		
<a href="#">Click here for the FIRST BASE Load Capacity Chart</a>		



Side view ( 1 : 16 )

3D view ( 1 : 16 )

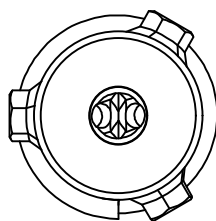

Top view ( 1 : 4 )

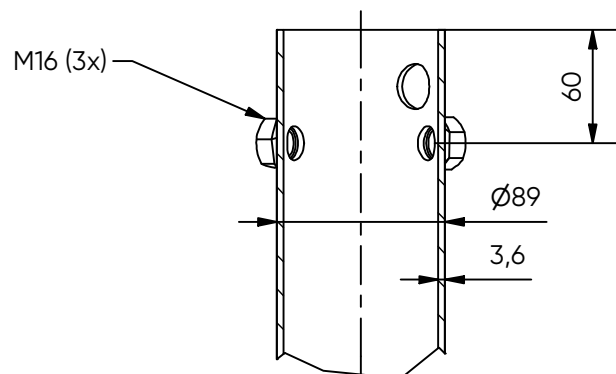

B-B ( 1 : 4 )

CE-certificate conform EN1090