

FIRST BASE Ground Screw

G3 Ø76 x 3,6 x 800mm, Nut 3 x M16

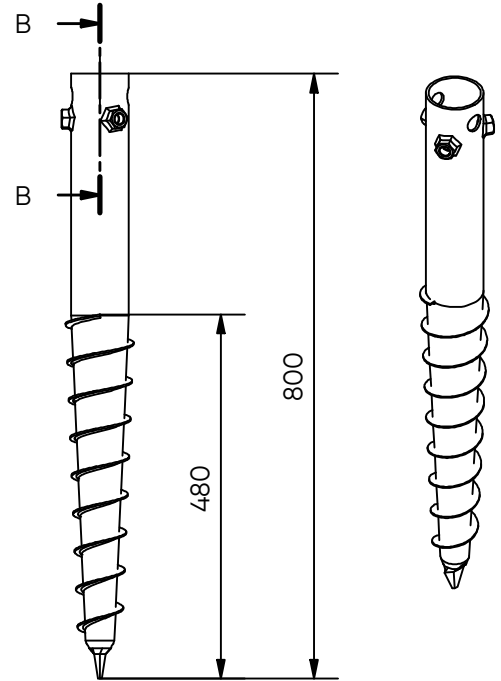

Art. No:	31020	
Weight:	4,6 kg	
Dimensions:	Pipe: 76,1 x 3,6 x 800 mm	
Materials:	Steel grade Pipe: S235 Surface treatment: Galvanized acc. to EN-ISO 1461	
Installation:	Electric machine 5.000Nm Art.No: 12001	Pneumatic machine 10.800Nm Art.No: 12005
	Hydraulic machine 7.500Nm Art.No: 120950	Hydraulic machine 12.000Nm Art.No: 120960
Use:	Light construction e.g. Solar Field-setups	
Fixation:	M16	
Products to combine:		
Click here for the FIRST BASE Load Capacity Chart		



Side view (1 : 10)

3D view (1 : 10)

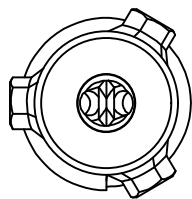

Top view (1 : 4)

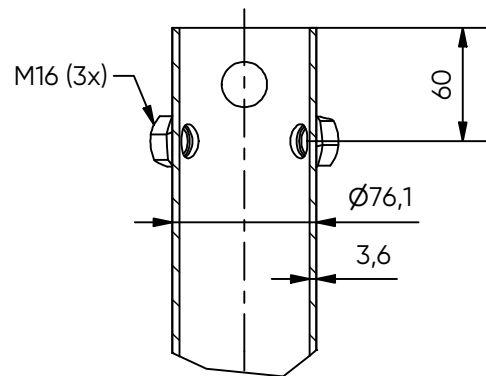

B-B (1 : 4)

CE-certificate conform EN1090