

FIRST BASE

Ground Screw $\text{Ø}68 \times 2 \times 800 \text{ mm}$

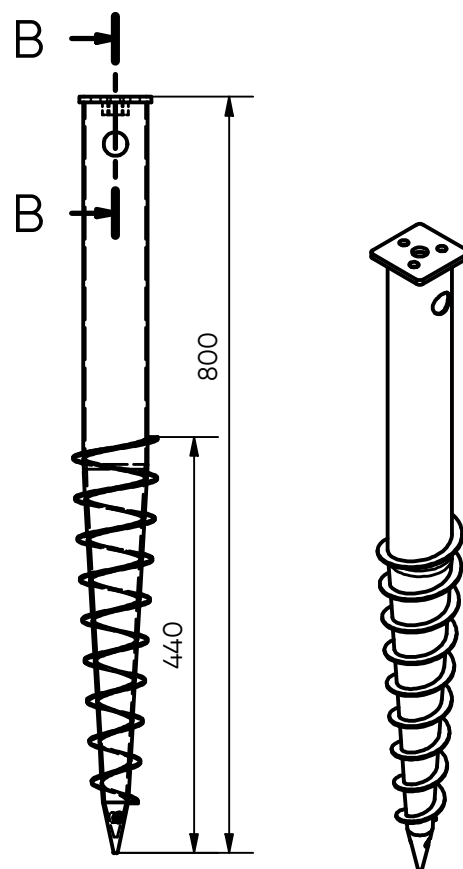

Art. No:	11007	
Weight:	2,9 kg	
Dimensions:	Pipe: 68 x 2 x 800 mm Flange: 6,0 x 76 x 76 mm	
Materials:	Steel grade Pipe: S235 Steel grade Flange: S355 Surface treatment: Galvanized acc. to EN-ISO 1461	
Installation:	Electric XE 2.5 machine Art.No: 12002	Manual mounting bar 22x800 Art.No: 12050
Use:	Light construction e.g. porches, garden rooms.	
Fixation:	M16 Bolts	
Products to combine: 58135 - POLE HOLDER M16 58131 - U-BRACKET		
Click here for the FIRST BASE Load Capacity Chart		



Side View (1 : 8)

3D view (1 : 8)

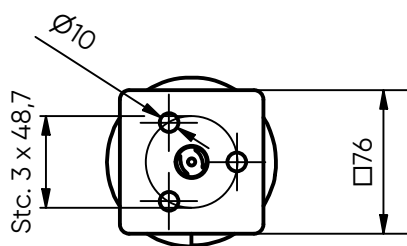

TOP view (1 : 4)

