

FIRST BASE V-76 x 2050 SCREW PART

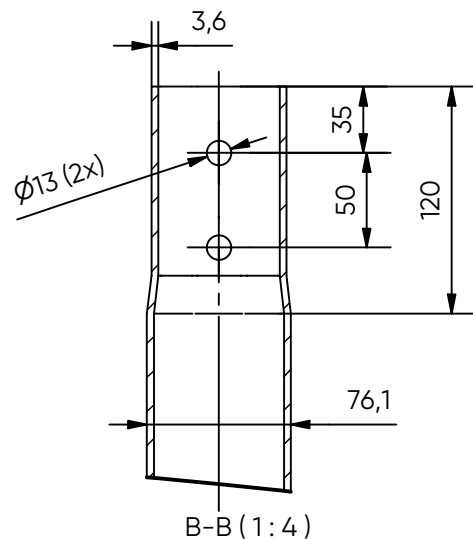

Art. No:	58203	
Weight:	13,2 kg	
Dimensions:	Pipe: 76,1 x 3,6 x 2050 mm	
Materials:	Steel grade Pipe: S235 Surface treatment: Galvanized acc. to EN-ISO 1461	
Installation:	Elektric machine 5.000Nm Art.No: 12001	Pneumatic machine 10.800Nm Art.No: 12005
	Hydraulic machine 7.500Nm Art.No: 120950	Hydraulic machine 12.000Nm Art.No: 120960
Use:	Construction e.g. porches, garden rooms and modular homes.	
Fixation:	M12 Bolts	
Products to combine:	58211 - V-76 EXTENSION 500mm 58212 - V-76 EXTENSION 1000mm 58213 - V-76 EXTENSION 1500mm 58214 - V-76 EXTENSION 2000mm 58220-V-76 ROUND FLANGE 80mm M16 58221 - V-76 ROUND FLANGE 200mm M16 58224 -V-76 ROUND FLANGE 200mm M20	
Click here for the FIRST BASE Load Capacity Chart		

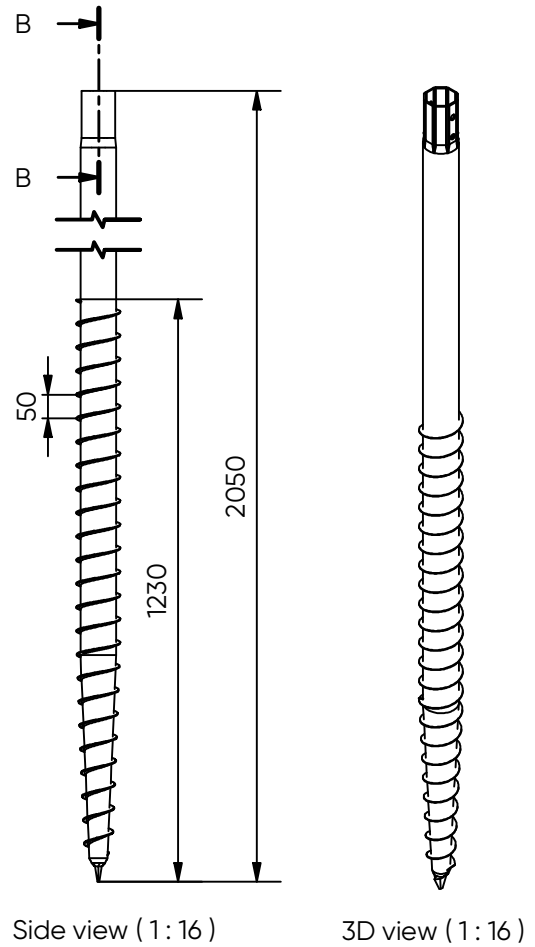

CE-certificate conform EN1090