

FIRST BASE Ground Screw

Ø76 x 2500mm - M16

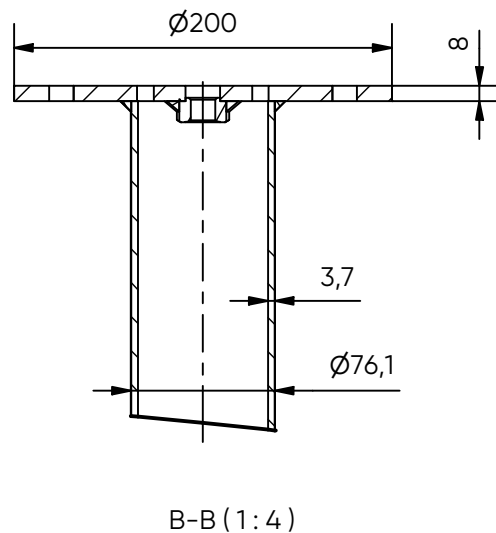

Art. No:	11045	
Weight:	18,0 kg	
Dimensions:	Pipe: 76,1 x 3,6 x 2500 mm Flange: 8,0 x 200 mm	
Materials:	Steel grade Pipe: S235 Steel grade Flange: S355 Surface treatment: Galvanized acc. to EN-ISO 1461	
Installation:	Electric machine 5.000Nm Art.No: 12001 Pneumatic machine 10.800Nm Art.No: 12005 Hydraulic machine 7.500Nm Art.No: 120950 Hydraulic machine 12.000Nm Art.No: 120960	
Use:	Light construction e.g. porches, garden rooms and modular homes.	
Fixation:	M16 / M12 / M10 Bolts	
Products to combine:	17021 - POLEHOLDER M20 17022 - L-BRACKET M16 - L-180x202x80x8mm 17024.1 - L-BRACKET M16 - L-120x80x105mm 17042 - ALUMINUM FILLER PLATE 70101 - FLANGEPLATE ENLARGER 12x300x300mm 8xM12 (S355) 70111 - STEEL SHIM 2x200mm FOR ROUND FLANGE 8x200mm 70112 - STEEL SHIM 5x200mm FOR ROUND FLANGE 8x200mm	
Click here for the FIRST BASE Load Capacity Chart		

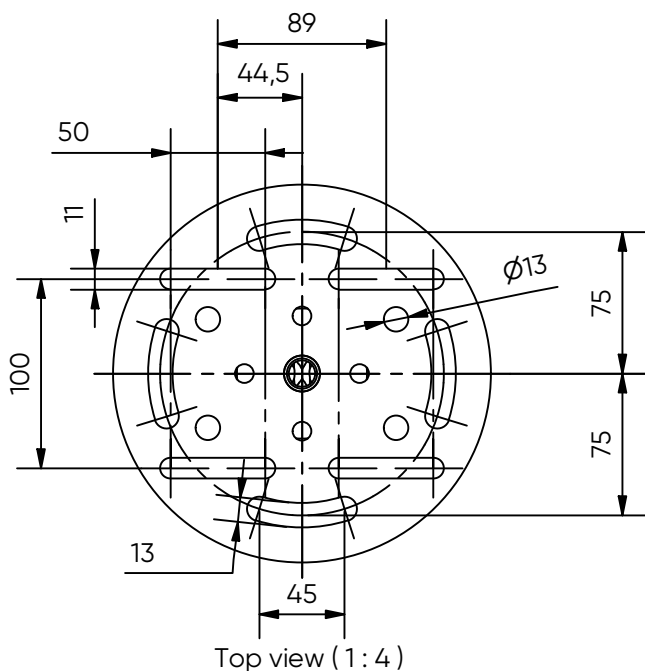
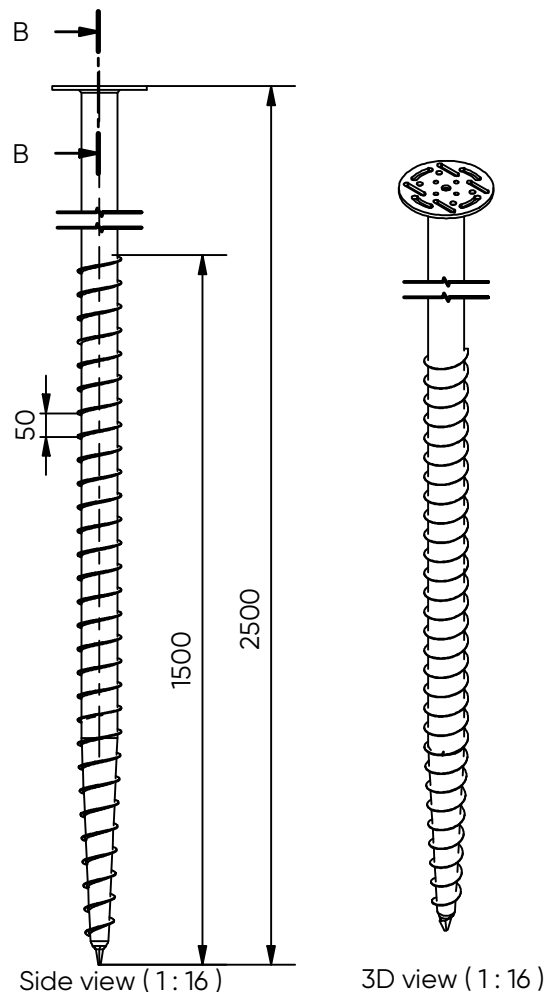

CE-certificate conform EN1090